

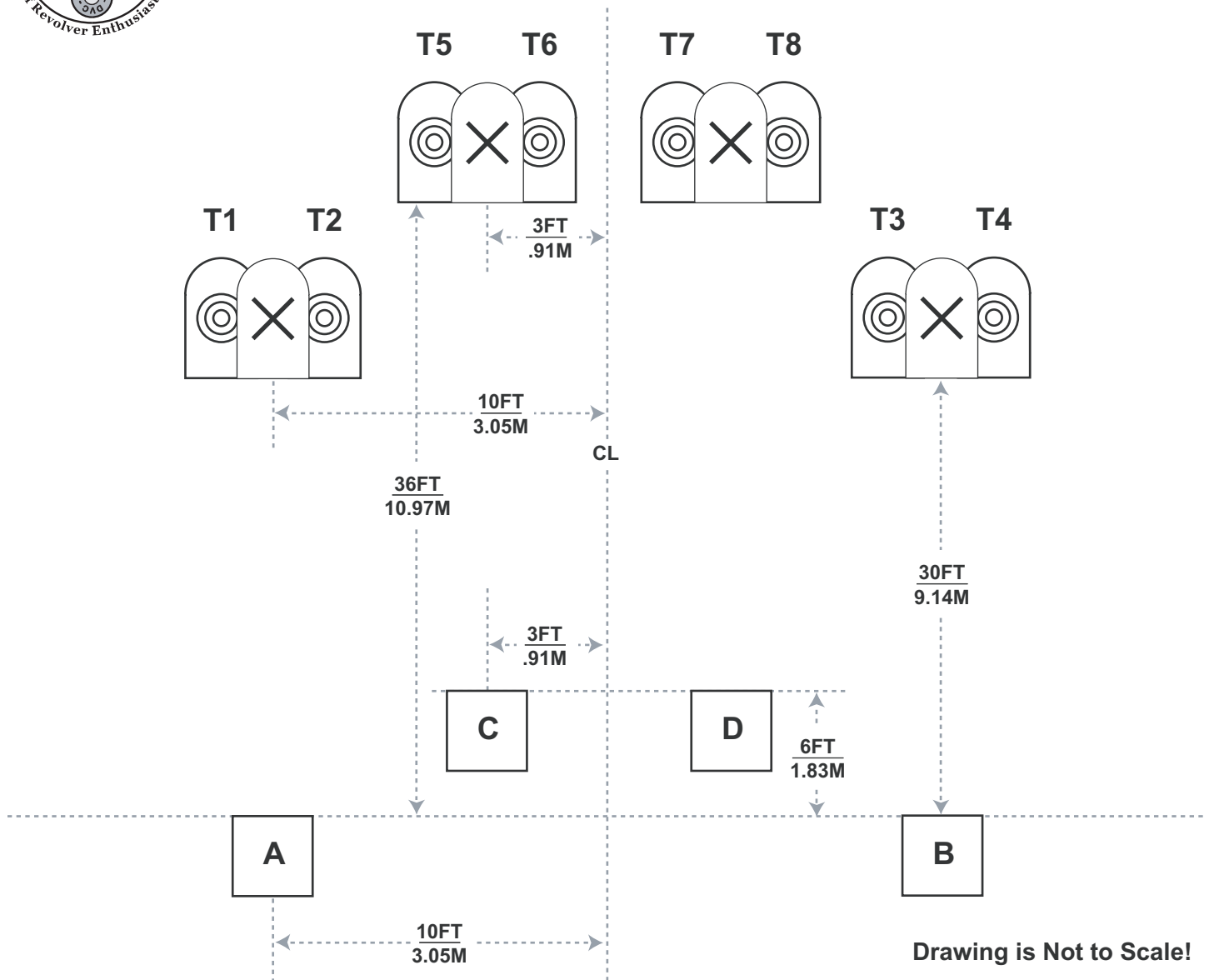

# Time To Fly

**CS-014**  
 Designed by  
**Steven Bressan**



**Drawing is Not to Scale!**

**Start Position:** Standing in Box A or Box B, facing downrange, hands relaxed at sides.

**Procedure:**

At start signal, from Box A engage only T1 and T2 with only three (3) rounds each in any order. From Box B, engage only T3 and T4 with only three (3) rounds each in any order. From Box C, engage only T5 and T6 with only three (3) rounds each in any order. From Box D, engage only T7 and T8 with only three (3) rounds each in any order.

Shooting from Boxes A and B must be completed before moving to Boxes C and D.

**Scoring:** Shots Limited

**Targets:** 8 NRA D-1 paper

**Rounds:** 24 maximum

**Start:** Audible

**Stop:** Last shot

**Penalties:** Per the ICORE rulebook. Foot faults, extra shots, extra hits, procedurals and misses +5 seconds per occurrence.

**Stage Setup:** Place targets per drawing dimensions. Set targets T1 thru T8 at standard height with top of target 1.65 m (5 feet 6 inch) +/- 5cm (2 inches) from ground. Place No-Shoots with edge touching A-ring of shoot targets. Alignment is shown to centerlines of boxes and targets, unless otherwise noted.

# CS-014

## Shots Limited

### Time to Fly



Target	A	B	C	M	Hits
T1					3
T2					3
T3					3
T4					3
T5					3
T6					3
T7					3
T8					3

R.O. \_\_\_\_\_

Shooter \_\_\_\_\_

Total Hits					24
------------	--	--	--	--	----

Time Factor	x0	x1	x2	x5
-------------	----	----	----	----

+  +

Extra Shots

Extra Hits

No Shoots

Procedurals

Notes

<input type="text"/>	Clock Time
<input type="text"/>	Hit Time Added
X5= <input type="text"/>	+ Extra Shots
X5= <input type="text"/>	+ Extra Hits
X5= <input type="text"/>	+ No Shoots
X5= <input type="text"/>	+ Procedurals
<input type="text"/>	Total

Name \_\_\_\_\_

ICORE Number \_\_\_\_\_

Date \_\_\_\_\_ Club \_\_\_\_\_

Limited / Open / Retro (Circle one)